



OPERATOR'S MANUAL

MODEL #100515
HOME STANDBY GENERATOR - 14KW



REGISTER YOUR PRODUCT ONLINE

at championpowerequipment.com



or visit championpowerequipment.com

SAVE THESE INSTRUCTIONS. This manual contains important safety precautions which should be read and understood before operating the product. Failure to do so could result in serious injury. This manual should remain with the product.

Specifications, descriptions and illustrations in this manual are as accurate as known at the time of publication, but are subject to change without notice.

No part of this publication may be reproduced or used in any form by any means – graphic, electronic or mechanical, including photocopying, recording, taping or information storage and retrieval systems – without the written permission of Champion Power Equipment (CPE).

FREE OFFER!

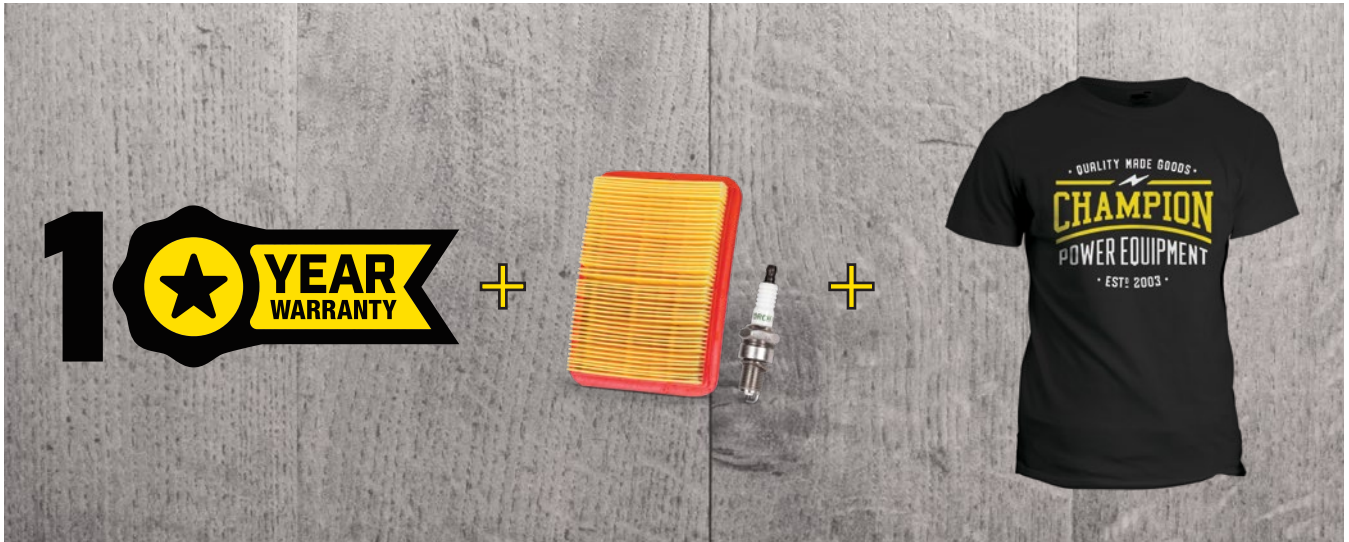

www.championpowerequipment.com/HSB-offer

REGISTER YOUR PRODUCT TODAY TO:



- Activate your 10 Year Warranty
- Receive FREE generator maintenance kit
- Receive FREE limited edition Champion t-shirt

THE FOLLOWING INFORMATION IS ALL YOU NEED TO COMPLETE THE ONLINE FORM:

- Full name
- Address where installed
- Phone
- Email
- T-shirt size
- Complete model number*
(generator + automatic transfer switch)
- Generator serial number
- Purchase date

Promotional offer valid for one home standby generator purchase per household. Please allow up to a total of 15 business days for your registration to be verified and free items to be mailed out. Your 10 year warranty is activated immediately upon submitting product registration through our website. Maintenance kit contents are model specific and include spark plug, air filter, and oil filter (where applicable). Contact Champion directly at 1-877-338-0999 with any questions.

**Complete model number can be found on purchase receipt.*

Have questions or need assistance?
Do not return this product to the store!

WE ARE HERE TO HELP!

Visit our website:

www.championpowerequipment.com

for more info:

- Product Info & Updates
- Tech Bulletins
- Frequently Asked Questions
- Product Registration

– or –

Call our Customer Care Team Toll-Free at:

1-877-338-0999

This manual must be used with Champion Power Equipment (CPE) manuals:

Installation Manual, Part No. 101951

Transfer Switch Manual, Part No. 101948

**We are always working to improve our products. Therefore, the enclosed product may differ slightly from the image on the cover.*

TABLE OF CONTENTS

Introduction **5**

Home Standby Generator **5**

Safety **5**

 Safety Definitions 5

 Safety Symbols 6

Important Safety Instructions **8**

 Installation Hazards 8

 Before Starting 8

 Operation Hazards 9

 Accidental Starting 9

 Carbon Monoxide Hazards 9

 Electrical Shock Hazards 10

 Fire/Explosion Hazards 10

 Burn Hazards 10

 Entanglement Hazards 10

 Battery Hazards 10

Safety Labels and Hang Tags **11**

 Safety label and Hang Tag locations 13

General Information **14**

 Component Identification - 14 kW Generator 14

 Component Identification – Engine 15

 Control Panel 15

 aXis Controller™ Module 15

 aXis Controller™ Module 16

 aXis Controller Module Fault Icons 17

 Programming aXis Controller™ 19

 Battery Charger 20

 Emission Requirements 20

 Specifications 21

 Fuel System 22

 Battery Requirements 22

 Battery Charging 22

 Model and Serial Number 22

Operation **23**

 Enclosure and Access 23

 Pre-Start Checklist 23

 Turning OFF the Generator 23

Maintenance **24**

 Scheduled Maintenance Chart 24

 Engine Oil 24

 Changing the Engine Oil 25

 Inspect and Clean Engine Air Cleaner 25

 Spark Plug 26

 Battery Maintenance 26

 Corrosion Protection 26

 Maintenance After Submersion 26

 Storage 27

 Return to Service after Storage 27

Troubleshooting HSB **28**

Additional Information **30**

 Identify/Select Standby Circuits 30

 Surge Protection 30

 Customer Familiarization Summary 30

 HSB, ATS Model & Serial Reference ATS Back-up Circuits 31

 Maintenance and Service Record 32

INTRODUCTION

Congratulations on your purchase of a Champion Power Equipment (CPE) product. CPE designs, builds, and supports all of our products to strict specifications and guidelines. With proper product knowledge, safe use, and regular maintenance, this product should bring years of satisfying service.

Every effort has been made to ensure the accuracy and completeness of the information in this manual at the time of publication, and we reserve the right to change, alter and/or improve the product and this document at any time without prior notice.

CPE highly values how our products are designed, manufactured, operated, and serviced as well as providing safety to the operator and those around the generator. Therefore, it is **IMPORTANT** to review this product manual and other product materials thoroughly and be fully aware and knowledgeable of the assembly, operation, dangers and maintenance of the product before use. Fully familiarize yourself, and make sure others who plan on operating the product fully familiarize themselves too, with the proper safety and operation procedures before each use. Please always exercise common sense and always err on the side of caution when operating the product to ensure no accident, property damage, or injury occurs. We want you to continue to use and be satisfied with your CPE product for years to come.

When contacting CPE about parts and/or service, you will need to supply the complete model and serial numbers of your product. Transcribe the information found on your product's nameplate label to the table below

| |
|-----------------------------------|
| CPE TECHNICAL SUPPORT TEAM |
| 1-877-338-0999 |
| MODEL NUMBER |
| 100515 |
| SERIAL NUMBER |
| |
| DATE OF PURCHASE |
| |
| PURCHASE LOCATION |
| |

HOME STANDBY GENERATOR

This home standby generator is intended exclusively for outdoor installation. This generator will operate using either liquified petroleum gas (LPG) or natural gas (NG).

This generator is designed to supply typical home load such as:

Induction motors – sump pumps, refrigerators, air conditioners, furnaces

Electronic items – televisions, computers

Household lighting

Microwaves

This generator is not intended for use in critical life support applications.

Proper sizing of the generator is required to ensure proper operation of appliances. Some appliances require additional wattage to start and must be considered.

SAFETY

Safety Definitions

The purpose of safety symbols is to attract your attention to possible dangers. The safety symbols, and their explanations, deserve your careful attention and understanding. The safety warnings do not by themselves eliminate any danger. The instructions or warnings they give are not substitutes for proper accident prevention measures.

DANGER

DANGER indicates a hazardous situation which, if not avoided, will result in death or serious injury.

WARNING

WARNING indicates a hazardous situation which, if not avoided, could result in death or serious injury.

CAUTION











CAUTION indicates a hazardous situation which, if not avoided, could result in minor or moderate injury.



NOTICE

NOTICE indicates information considered important, but not hazard-related (e.g., messages relating to property damage).

Safety Symbols

Some of the following symbols may be used on this product. Please study them and learn their meaning. Proper interpretation of these symbols will allow you to more safely operate the product.

| SYMBOL | MEANING |
|---|--|
|  | Read Operator's Manual. To reduce the risk of injury, user must read and understand operator's manual before using this product. |
|  | Eye protection. Always wear eye protection with side shields marked to comply with ANSI Z87.1 |
|  | Wear personal protective equipment |
|  | Safety alert symbol |
|  | Asphyxiation hazard |
|  | Electrical shock hazard |
|  | Entanglement hazard |
|  | Fire hazard |
|  | Fire/Explosion. Fuel and its vapors are extremely flammable and explosive. Fire or explosion can cause severe burns or death. |
|  | Hot Surface. To reduce the risk of injury or damage, avoid contact with any hot surface. |

| SYMBOL | MEANING |
|--|-------------------------------|
|  A yellow triangular warning sign with a black border. Inside the triangle, a black silhouette shows a hand reaching towards a rotating blade. | Sever hazard (rotating blade) |
|  A yellow triangular warning sign with a black border. Inside the triangle, a black silhouette shows a hand reaching towards the top of a machine, indicating a crush hazard. | Crush hazard (top) |

IMPORTANT SAFETY INSTRUCTIONS

⚠ WARNING

Cancer and Reproductive Harm – www.P65Warnings.ca.gov

⚠ DANGER

Generator exhaust contains carbon monoxide, a colorless, odorless, poisonous gas. Breathing carbon monoxide will cause nausea, dizziness, fainting or death. If you start to feel dizzy or weak, get to fresh air immediately.

GENERATOR MUST BE INSTALLED AND OPERATED OUTDOORS ONLY.

Carbon monoxide (CO) poisoning symptoms include but are not limited to the following:

- Lightheadedness, dizziness, blurred vision
- Physical fatigue, weakness in joints and muscles
- Mental fatigue, sleepiness, inability to concentrate or speak clearly,
- Stomachache, vomiting, nausea

In the event of carbon monoxide (CO) poisoning:

- Seek fresh air immediately
- DO NOT sit, lie down or fall asleep.
- Alert others to the possibility of carbon monoxide (CO) poisoning.
- If the affected person does not improve within minutes of breathing fresh air, call 911 immediately for medical assistance.

⚠ WARNING

Do not use generator for medical and life support uses.

In case of emergency, call 911 immediately.

NEVER use this product to power life support devices or life support appliances.

NEVER use this product to power medical devices or medical appliances.

Inform your electricity provider immediately if you or anyone in your household depends on electrical equipment to live.

Inform your electrical provider immediately if a loss of power would cause you or anyone in your household to experience a medical emergency.

Installation Hazards

⚠ WARNING

Have only a qualified electrician or installation technician who is familiar with applicable codes, standards and regulations install and service the generator.

ALWAYS comply with local, state and national electrical and building codes when installing the generator. NEVER alter the recommended installation in a way that would render the unit noncompliant with these codes.

ALWAYS comply with regulations that Occupational Safety and Health Administration (OSHA) has established.

ENSURE the generator is installed following the manufacturer's instructions.

Before Starting

⚠ CAUTION

Before operation, read and understand the features and controls of the generator, including the safety information of this manual.

The owner/operator is responsible for safe operation and maintenance of the generator. Be sure all potential users of the generator also understand these instructions. If any portion of this manual is not understood, contact your dealer for assistance before operating the generator.

The operator is responsible for performing all safety checks, making sure all maintenance is properly performed and making sure the generator is periodically checked by the dealer.

Inspect the generator regularly. Contact your dealer if repairs are needed.

NEVER climb or step on any part or components of the generator. Doing so may result in injury and cause leaking fuel and exhaust.

Operation Hazards

WARNING

ALWAYS operate the generator following the manufacturer's instructions. Operating the generator improperly or neglecting maintenance can result in serious injury or possible death.

DO NOT allow children or unqualified persons to operate or service the generator.

NEVER operate the generator with the covers open. Operate the generator only with the covers closed and secured in place. NEVER leave the covers unlocked.

Remain alert at all times when working on the generator. NEVER work on the generator when physically or mentally fatigued.

NEVER operate the generator while under the influence of alcohol or drugs.

Accidental Starting

WARNING

ALWAYS prevent the generator from starting while the covers are open. The generator may crank and start at any time without notice. Follow these steps in order:

1. Pull fuse from aXis Controller™ panel and secure with tape to the panel.
2. Disconnect the NEGATIVE, NEG or (-) battery cable first, and then remove the POSITIVE, POS or (+) battery cable.

To return the generator to service, follow these steps in order:

1. Connect the POSITIVE, POS or (+) battery cable first, and then connect the NEGATIVE, NEG or (-) battery cable.
2. Remove taped fuse from the panel and reinstall into the aXis Controller™ module.

Carbon Monoxide Hazards

DANGER

- Generator must be installed and operated outdoors only.
- NEVER allow exhaust fumes to enter a confined area through windows, doors, air intake vents or other openings of the building
- ALWAYS avoid breathing exhaust fumes when near an operating generator.
- NEVER alter the generator or modify the exhaust system thereby creating noncompliance with Federal and State emissions regulations, local applicable codes, standards and laws.
- NEVER allow blockage of the engine's air intake cooling ventilation system. Doing so can seriously affect performance and safe operation of the generator.
- Install a battery-operated carbon monoxide (CO) detector on each level of any building adjacent to the generator location following the manufacturer's CO detector installation instructions.

NOTICE

In many States it is required by law to have a Carbon Monoxide (CO) detector on each level of any building in operating condition.

Carbon Monoxide (CO) is a colorless, odorless, poisonous gas. Breathing carbon monoxide will cause nausea, dizziness, fainting or death.

A Carbon Monoxide (CO) detector is a device that detects elevated hazardous levels of CO and will alert the occupants by flashing a visual light indicator and an audible alarm.

Electrical Shock Hazards

⚠ WARNING

Use extreme caution when near the generator while it is operating. The generator produces dangerous voltage.

- Avoid contact with bare wires, terminals and connections while the generator is operating.
- ALWAYS stand on an insulated dry surface to reduce shock hazard if work must be done on an operating generator.
- NEVER wear jewelry that can conduct electricity when working on the generator.
- NEVER handle any kind of electrical device while hands or feet are wet, while standing in water or while barefoot.
- Proper earth grounding of the frame and external electrical conductive components is required by the National Electrical Code (NEC). State and local codes for proper grounding may also apply.
- Avoid direct contact with an electric shock victim. Immediately shut down the source of electrical power. If this is not possible, attempt to free the victim from the live conductor using a nonconducting item such as a dry board or rope. If the victim is unconscious, apply first aid and call 911 immediately.

Fire/Explosion Hazards

⚠ WARNING

Natural Gas (NG) and Liquefied Petroleum Gas (LPG) are extremely explosive.

- NEVER allow any flames or smoke near the fuel system.
- Wipe up any oil spills immediately.
- NEVER allow any combustible materials to be near the generator or to be left in the generator compartment.
- ALWAYS keep the surrounding area near the generator clean and free of debris.
- Be sure to properly purge the fuel lines and leak-test according to applicable codes before placing the generator in service.
- Be sure to regularly inspect the fuel system for leaks. NEVER operate the generator if a fuel leak is present.
- Install a fire extinguisher near the generator. Keep it properly charged and be familiar with its use. An ABC rated National Fire Protection extinguisher is appropriate for use on standby electric systems. Contact your local fire department with any questions concerning the fire extinguisher.

Burn Hazards

⚠ WARNING

DO NOT touch hot surfaces.

- ALWAYS avoid contact with hot exhaust components and gases. Running engines produce heat. Severe burns can occur on contact.
- ALWAYS allow hot surfaces to cool to the touch.

Entanglement Hazards

⚠ WARNING

Use extreme caution when near rotating parts. Rotating parts can entangle hands, feet, hair, clothing and/or accessories. Traumatic amputation or severe laceration can result.

- Keep hands and feet away from rotating parts.
- Tie up long hair and remove jewelry.
- Operate equipment with guards in place.
- DO NOT wear loose-fitting clothing, dangling drawstrings or items that could become caught.

Battery Hazards

⚠ WARNING



Always read and comply with the battery manufacturer's recommendations for procedures concerning proper battery use and maintenance.



Batteries contain sulfuric acid and generate explosive mixtures of hydrogen and oxygen gases. Keep any device that may cause sparks or flames away from the battery to prevent explosion.



Always wear protective glasses or goggles and protective clothing when working with batteries. You must follow the battery manufacturer's instructions on safety, maintenance and installation procedures.





SAFETY LABELS AND HANG TAGS

⚠ WARNING

DO NOT operate the generator if there are missing or badly worn safety labels. Safety labels must be legible to alert personnel of safety hazards.

- Replace any illegible or missing label immediately. Missing safety labels must be replaced in their original position before the generator is operated.

Labels

| | LABEL | DESCRIPTION | PART NO. |
|---|---|-------------------------------|-----------|
| A |  | Poison, Burn and Fire Warning | 2510-L-SF |
| B |  | Burn Warning | 2483-L-SF |
| C |  | Electrocution Warning | 2396-L-SF |
| D |  | Burn Warning | 2473-L-SF |
| E |  | Electrocution Warning | 2474-L-SF |

| LABEL | | | DESCRIPTION | PART NO. |
|-------|--|--|--|-----------|
| F | | | Explosion Warning, Read OM, Starting Warning | 2470-L-SF |
| | | | | |
| | | | | |
| | | | | |

Hang Tags

| HANG TAG | | DESCRIPTION | PART NO. |
|----------|--|------------------------|-----------|
| 1 | | Alternate Power Source | 1681-T-OP |

Safety label and Hang Tag locations

The safety labels have specific placement and must be replaced if they are unreadable, damaged or missing.

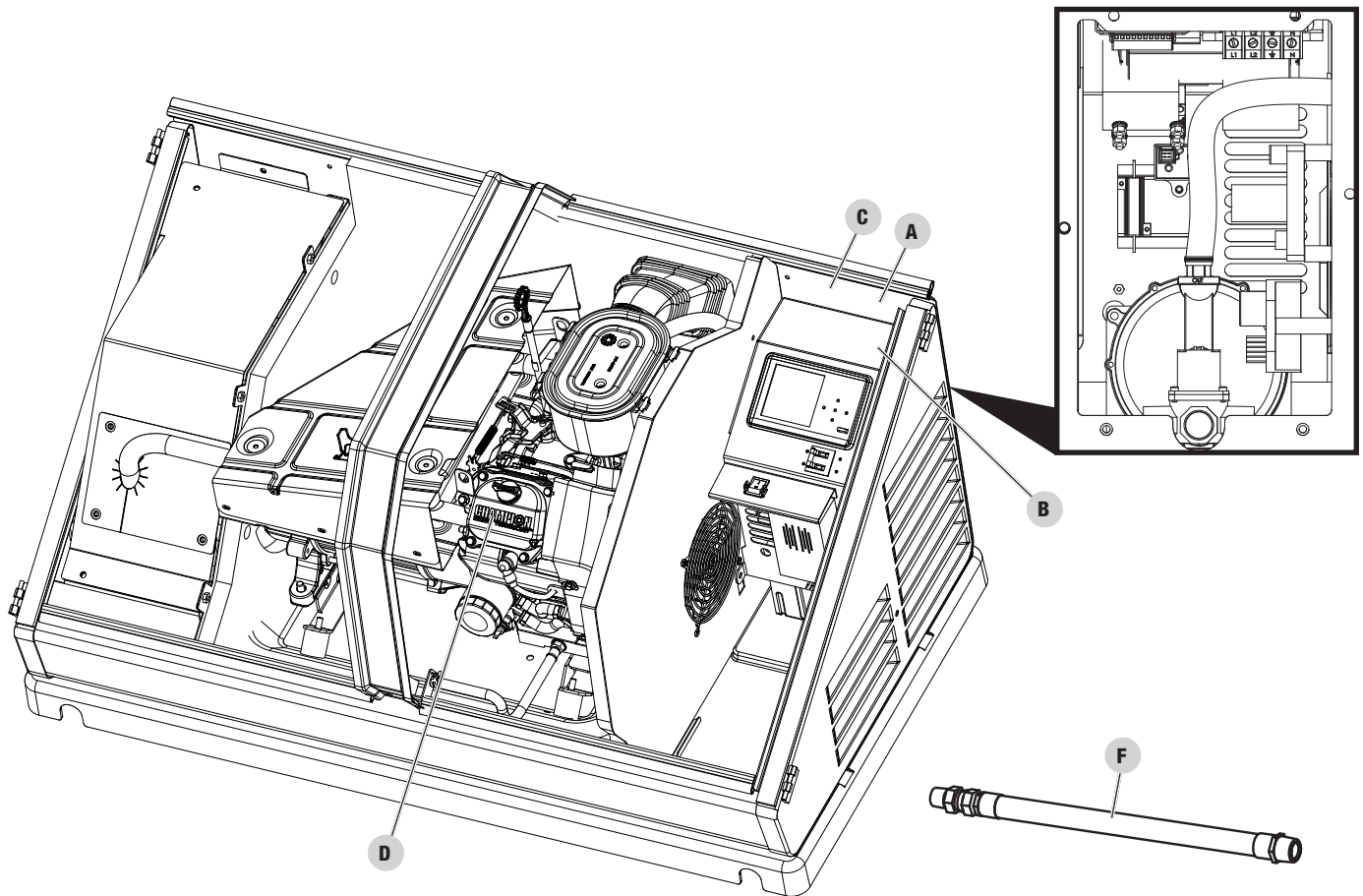

- a. Serial number location
- b. Nameplate
- c. NFPA 37 Compliance
- d. Oil hang tag
- e. Alternate power source (not shown – in the OM bag)
- f. Flexible Fuel Line hang tag

GENERAL INFORMATION

Component Identification - 14 kW Generator

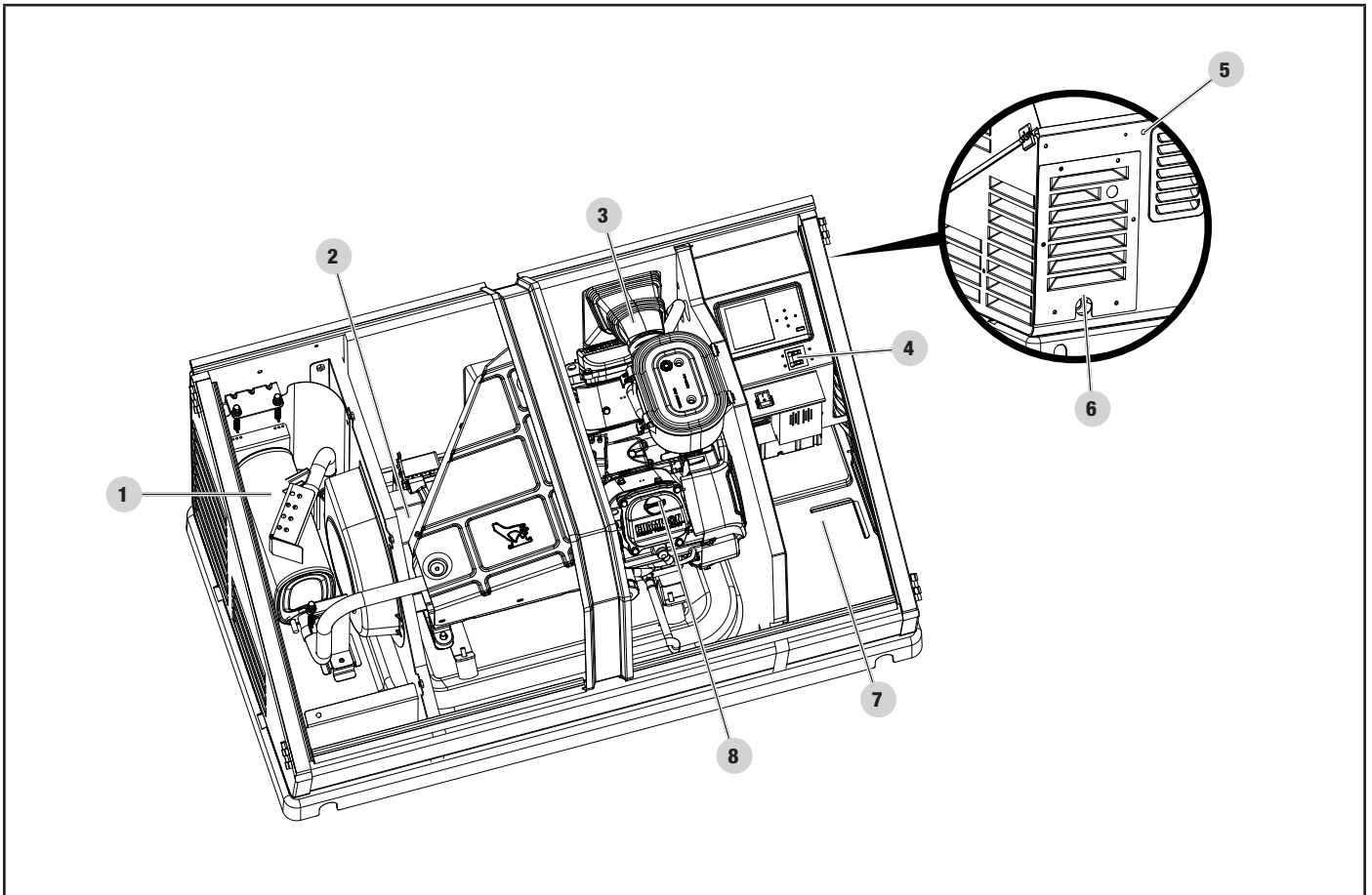

- | | |
|-------------------------|---|
| 1. Exhaust System | 5. Exterior Fault Code Indicator Light |
| 2. Alternator | 6. Fuel Regulator/Wire Connections (behind panel) |
| 3. Air Inlet | 7. Batteries (not included) |
| 4. Main Circuit Breaker | 8. Engine |

Component Identification – Engine

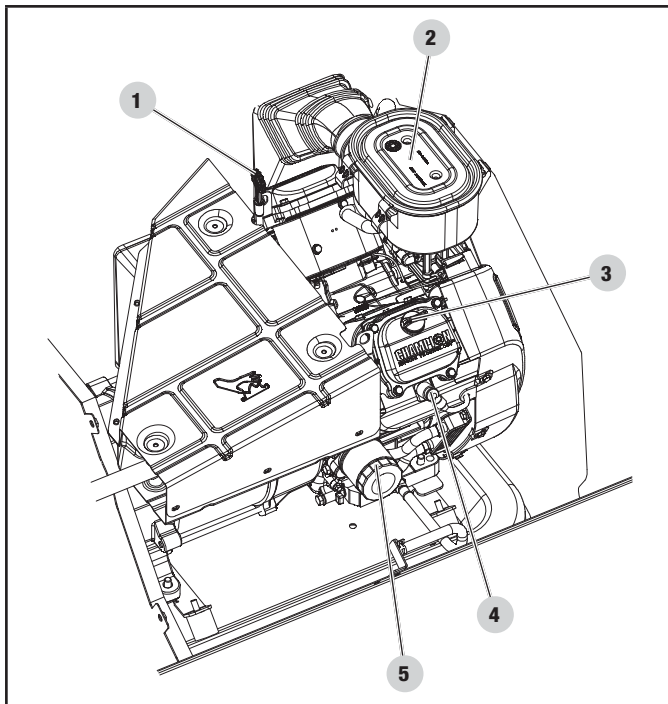

- 1. Engine Oil Dipstick
- 2. Air Cleaner
- 3. Oil Cap
- 4. Spark Plug (second on opposite side)
- 5. Oil Filter

Control Panel

MAIN CIRCUIT BREAKER

The 65-amp main circuit breaker protects the generator from circuit overload. The main circuit breaker controls total output of the generator. The main circuit breaker must be in the ON position for the aXis ATS to communicate with this standby generator.

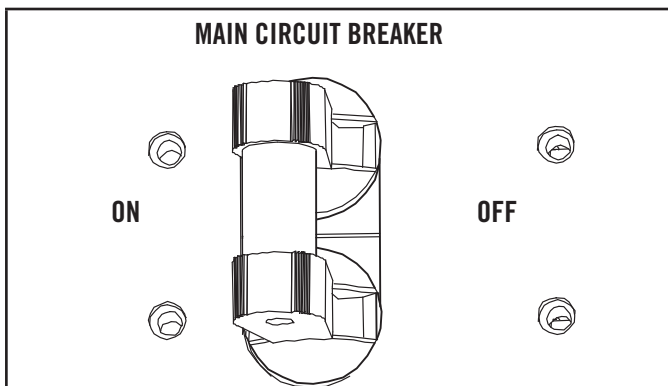

GENERATOR ON/OFF SWITCH

This generator has an ON/OFF switch that when turned off, will shut down the HSB (if running) and deactivate the aXis controller preventing future starts. This switch should be used in instances where the HSB needs to stay off regardless of utility power presence. When the switch is in the OFF position, the HSB will not exercise or start for any reason.

NOTE: If maintenance or service work is going to be performed on the generator or the home's electrical system, it is required accidental startup is further safeguarded by pulling the fuse from the aXis controller panel and disconnecting the batteries.

When the switch is in the ON position, the aXis controller will be energized and the HSB will be controlled by the programming of the aXis controller. The switch needs to be in the ON position in order for the HSB to be in AUTO mode.

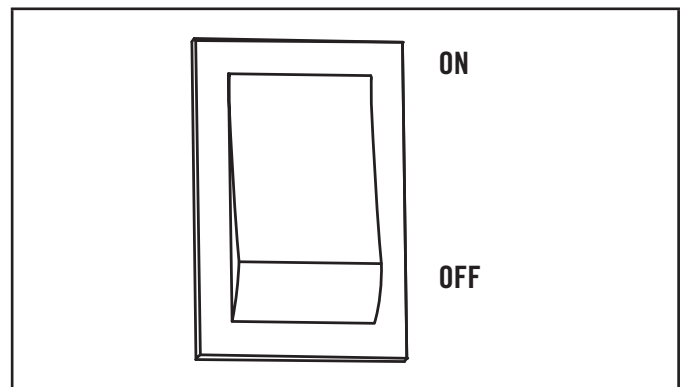

aXis Controller™ Module

aXis CONTROLLER MODULE PAD

The aXis Controller module is equipped to provide monitoring and protection for the HSB.

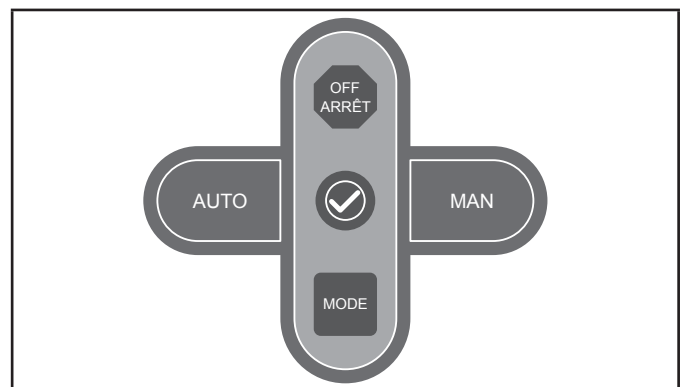

MAN

This button allows verification that the HSB power delivery circuit is functional. The engine will start in manual mode. Safety procedures should be followed. Prior to placing the aXis Controller module in the “MAN” mode, the UTILITY, ATS active and LOAD Icon will be lit.

AUTO

This button allows automatic delivery of power from the HSB when there is a utility power outage. With the controller in the AUTO position and the HSB not running (standby mode), the UTILITY, ATS active and LOAD icon will be lit (view left to right), this indicates the household is using Utility power. AUTO position is the standby ready position.

OFF

This button closes and shuts down the engine signals. It prevents the automatic operation of the generator. OFF is required when all maintenance or service are being performed on or around the unit.

MODE

This button allows user to cycle through screens of the aXis Controller module.

Cycles through available menus in run mode:

- DCV (first screen) – indicates current battery voltage
- HZ – indicates alternator frequency
- ACV – indicates alternator voltage
- HR – indicates total run hours on Home Standby
- Check button is used when programming of the aXis Controller module.

aXis Controller™ Module

aXis CONTROLLER MODULE STATUS ICONS

The status icons are located at the top of the aXis Controller.

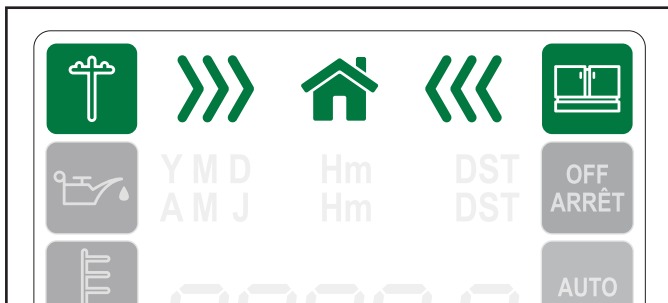

Utility Pole

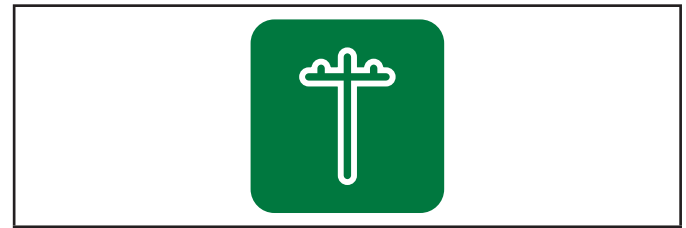

The utility pole icon will indicate power source when the utility is the source of power.

Transfer Power Direction

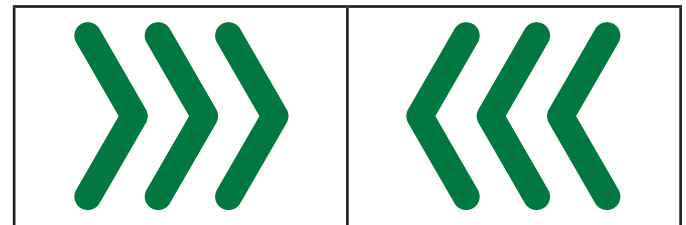

Shows the direction of power

House



Icon for house receiving power

HSB

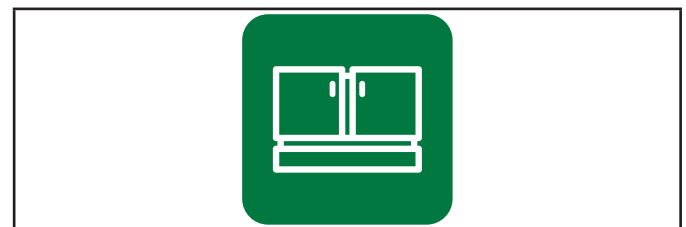

The HSB icon will indicate power when the generator is the source of power

aXis CONTROLLER MODULE INFORMATION ICONS

The information icons are located at the bottom right side of aXis Controller icon touch pad.

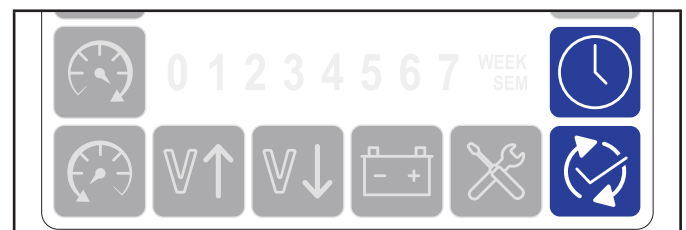

Hour Meter



The hour meter keeps track of all running time of the HSB. This includes run time during a utility power outage and during the weekly exercise cycle. This provides the owner with a record of operating time which is useful in keeping track of scheduled maintenance intervals. Refer to the scheduled maintenance chart in your Owner’s Manual for specific maintenance. The hour meter can’t be reset. The initial time registered on the meter when first started up (installed) will reflect the factory test time, this is a normal industry standard. The hour meter only reflects hours, it does not reflect RPMs or any other function.

Exercise Icon



The BLUE icons will be lit when the HSB is performing the weekly exercise period. Refer to “Setting Exercise Time” to establish the weekly exercise period. When the exercise period is complete the icon will turn off and the HSB will resume its standby monitoring.

aXis CONTROLLER MODULE FAULT ICONS

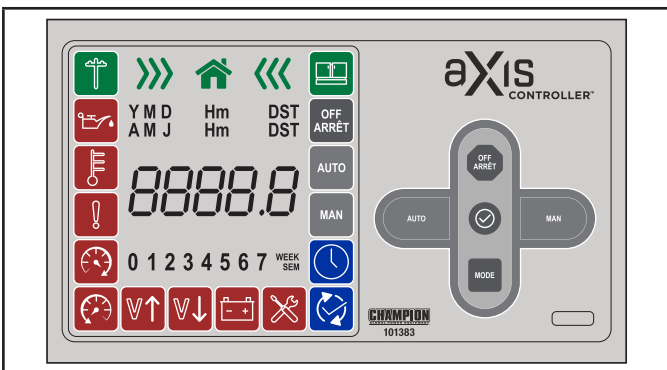

Low Oil

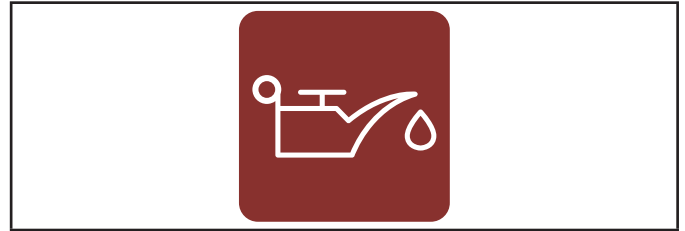

The RED icon will be lit when the engine oil level drops below the safe operating level. When this fault is detected, the HSB will shut down and re-start will be disabled. RED icon on the controller module and exterior LED will be lit.

Check the oil level. The oil level should be at the FULL mark, if necessary, add oil. DO NOT overfill. Inspect the unit for a possible oil leak, if a leak is discovered, contact Champion or your nearest Authorized Champion Dealer. Follow the reset procedures contained in the manuals specific to your model to clear and correct.

High Engine Temperature



The RED icon will be lit if the engine operating temperature exceeds the factory preset limits. If excessive operating temperature is detected, the HSB will shut down and re-start will be disabled. The RED icon on the aXis Controller module and exterior enclosure LED will be lit.

This failure could be the result of an excessive load or high ambient temperatures. Should this fault occur do the following;

1. Open the enclosure doors to increase air flow throughout the unit
2. Check oil level add oil if required
3. Inspect the interior and exterior of the enclosure for debris, leaves, etc., and remove them to increase air flow around and inside the unit.
4. Once the engine temperature falls into the normal operating range, generally 30 minutes, follow the reset procedures in the manuals specific to your model to clear and correct fault.
5. Close the enclosure doors and the unit is ready to run.

Over crank



The RED icon will be lit if the engine does not start after 5 attempts. This prevents the HSB from damaging itself or other related components. When the fault is detected, the HSB will shut down and re-start will be disabled. RED icon on the controller module and exterior LED will be lit.

This failure could be the result of insufficient fuel supply. Check the in-line fuel shut off valves and make sure they are in the ON/ OPEN position. Position them in the correct position, follow the reset procedures contained in the manuals specific to your model to clear and correct. If they are in the correct position and the HSB shows a fault light again, it's recommended to perform a Manometer pressure check by an Authorized Champion Dealer or installer. This will make sure the correct amount of fuel is being delivered to the HSB when it starts.

Insufficient battery output could result in poor cranking cycles, not permitting the engine starter to reach optimum starting RPM to start the engine. This can be verified by checking the Battery Charger icon, NO CHARGE. If this occurs, the individual battery voltages must be checked to determine if the batteries are properly charged or if they have failed. It is extremely important to follow all cautions and warning per the battery manufacturer concerning installation, service, maintenance and replacement procedures.

Hz Over speed/Under speed

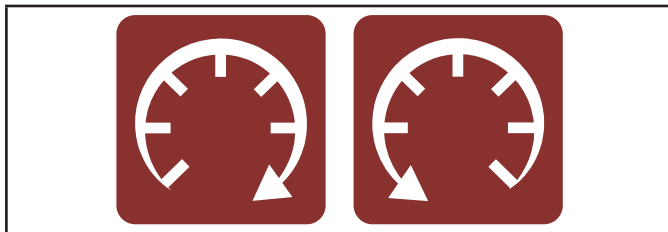

The RED icon will be lit if the engine was operating above or below its preset speed limits. These limits are factory set to protect the HSB and the circuits connected to the generator output circuits. When this fault occurs, the HSB will shut down, light the RED icon, shut down and re-start will be disabled. The exterior fault LED on the back of the HSB enclosure will be activated and lit.

Appliances connected to the generator circuit could be damaged from high generator output if the engine operates above the factory preset limits. If this failure occurs, contact Champion or your Authorized Champion Dealer. The RED icon will remain lit until the failure has been corrected, the HSB will not attempt to transfer or run.

Line Over Voltage



The RED icon will be lite if the HSB generator output power exceeds preset limits of 264 VAC.

When this fault occurs, the HSB will light the RED icon, shut down and re-start will be disabled. The exterior fault LED on the back of the HSB enclosure will be activated and lit. Check and adjust AVR. Set Voltage to 240 VAC.

Line Under Voltage



The RED icon will be lit if the HSB Generator output power is below preset limits of 216 VAC.

When this fault occurs, the HSB will light the RED icon, shut down and re-start will be disabled. The exterior fault LED on the back of the HSB enclosure will be activated and lit. Check and adjust AVR. Set Voltage to 240 VAC.

Low Battery

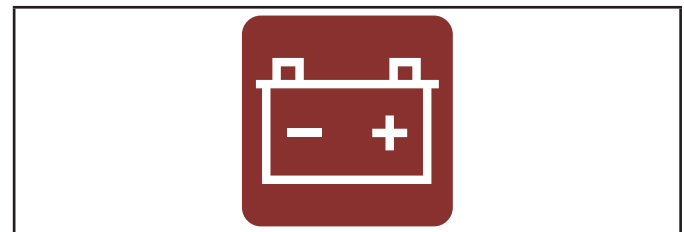

The RED icon will be lit if the battery voltage falls below 21.0 volts for at least 5 seconds while the engine is running. If the battery voltage rises above 22 volts, the icon will turn off. Battery voltage is NOT monitored when the engine is cranking, just when the engine is running. If the RED icon comes on it will not shut the HSB off, it will remain lit until the battery condition meets the required output.

When the icon remains lit, the battery charging should be checked and the condition of the batteries. Follow reset procedures contained in the manuals specific to your model to clear or correct.

Requires Maintenance



The RED icon will be lit if the HSB generator is ready for maintenance.

FAULT PROTECTION-CONTINUED

In all cases when the icon is RED, this is an indicator that the HSB has registered a fault and must be corrected. Only the “LOW BATTERY” and “MAINTENANCE” icons will not latch out or shut down the HSB. ALL other RED icon faults will latch out, shut down, disable starting and light the RED icon on the aXis Controller Module and the Exterior Fault Code icon on the backside of the HSB.

APPROXIMATE ENGINE STARTER CRANK CYCLE TIMES

- 10 seconds ON
- 10 seconds OFF
- (5 Cycles Total)

If the HSB fails to start, the “OVER CRANK” icon will be lit on the aXis Controller module and the exterior fault code indicator icon on the backside of the HSB.

FAULT CODE RESET

In the event a fault has occurred push OFF button to reset then MAN or AUTO button to re-arm.

⚠ WARNING

All faults should be taken seriously and corrected before reset process is performed.

Programming aXis Controller™

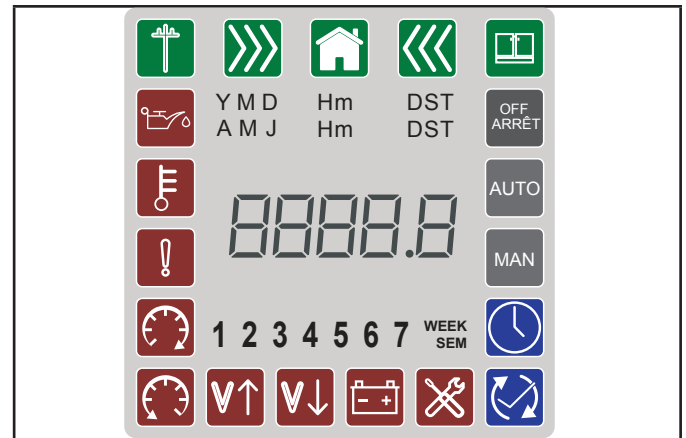

Hold button for 3 seconds (decimal point will flash) to enter set mode.

NOTE: Set values will be autosaved after 5 seconds of inactivity or after pressing the button. Pressing the OFF button will cancel any unsaved settings and return to the main menu.

1. Year (Y)
 - 1a. Set year using mode button
 - 1b. for next
2. Month (M)
 - 2a. Set month using mode button
 - 2b. for next
3. Day (D)
 - 3a. Set day using mode button
 - 3b. for next
4. Week
 - 4a. Set week using mode button
 - 4b. for next
5. Hour (H)
 - 5a. Set hour using mode button
 - 5b. for next
6. Minute (m)
 - 6a. Set minute using mode button
 - 6b. for next
7. Daylight Saving Time (DST)
 - 7a. Set DST on or off using mode button
 - 7b. for next
8. Hours for maintenance reminder (H)
 - 8a. Set hours for maintenance using mode button
 - 8b. for next

9. Exercise

9a. Set exercise using mode button

9b. for next

9c. Exercise Schedule:

- i. 0 - no exercise
- ii. 1 – 1 time per month
- iii. 2 – 2 times per month
- iv. 3 – 3 times per month
- v. 4 – 4 times per month

9d. Week (exercise)

9e. Set week using mode button

- i. 0 - Sunday
- ii. 1 - Monday
- iii. 2 - Tuesday
- iv. 3 - Wednesday
- v. 4 - Thursday
- vi. 5 - Friday
- vii. 6 - Saturday
- viii. for next

9f. Hour (exercise)

- i. Set hour using mode button
- ii. for next

9g. Minute (exercise)

- i. Set minute using mode button
- ii. for next

| | |
|-------------------|--|
| Power | Lit to indicate the battery is fully charged. |
| Small Bar | Lit to indicate the battery is receiving a trickle charge |
| Middle Bar | Lit to indicate current output is near 50%. |
| Large Bar | Lit to indicate the charger is operating above 50% capacity. |
| No Charge | Lit to indicate a battery charging problem. If this LED is lit, the LED on the Engine Controller module, "LOW BATTERY" will also be lit. |

Battery Charger

The LEDs on the battery charger indicate the state of the battery's charge level. Battery charger rating 24 Vdc 1.6A.

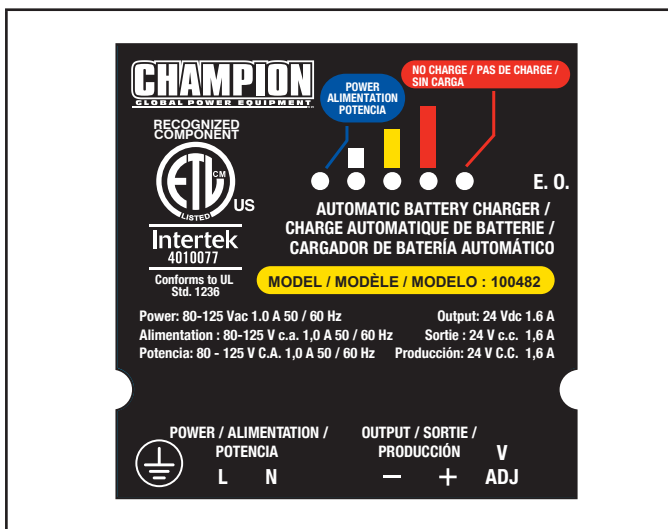

Emission Requirements

This engine-powered generator meets all United States Environmental Protection Agency (EPA) Phase 3 requirements and is approved for use in both the USA and Canada.

This generator is certified to operate on pipeline NG and LPG (vapor) fuel for use as a stationary engine for standby power generation. Federal and/or local laws may be violated if it is used for any other purpose.

The maintenance schedule must be followed to ensure that the engine complies with the applicable emission standards for the duration of the engine's life.

NOTICE

For Emission control devices and systems, read and understand your responsibilities for service as stated in the Emission Control Warranty Statement of this manual.

Specifications

| Home Standby Generator | |
|---|---|
| Maximum continuous power, LPG | 14 kW |
| Maximum continuous power, NG | 12.5 kW |
| Rated voltage | 120/240 |
| Amps | 116.6/58.3 LPG (propane), 104/52 NG (natural gas) |
| Harmonic distortion | Less than 5% |
| Main line circuit breaker | 65 amp |
| Phase | Single |
| Frequency | 60 Hz |
| Unit weight | 446.4 lb. (202.5 kg) |
| Size (L x W x H) | 49 x 28 x 28 in. (124.5 x 71 x 71 cm) |
| Engine | |
| Type | Milwaukee Series OHV Commercial V-Twin |
| No. of cylinders | 2 |
| Displacement | 754 cc |
| Cylinder block | Aluminum with cast iron sleeves |
| Ignition system | Solid state – magneto |
| Spark plug | F7RTC (NGK BPR7ES) |
| Governor | Mechanical |
| Starter | Electric 24V DC |
| Oil capacity | 1.6 qt (1.5 L) |
| Oil Type | 5W-30 Full Synthetic* |
| RPM | 3600 |
| Controls | |
| Mode switch auto | Auto start on utility failure |
| Mode switch manual | Starts on demand |
| Mode switch off | Stops unit/control and charger active |
| Ready to run/maintenance messages | Standard |
| Programmable start delay | Standard |
| Engine start sequence | Standard |
| Starter lockout | Standard |
| Battery charger/low battery indicator | Standard |
| Charger fault | Standard |
| AVR over voltage protection | Standard |
| Low oil protection | Standard |
| Safety fused | Standard |
| Overcrank/overspeed/underspeed protection | Standard |

*Unit ships without oil. Add oil before starting the HSB.

Fuel System

The engine is fitted with a dual master mixer assembly carburetion system, which allows it to run on either NG or LPG. It has been configured at the factory to run on NG. If your installation requires the engine to run on LPG, orifices in the master mixer assembly carburetor must be changed.

Battery Requirements

Two (2) 12 volt Group U1 batteries with a minimum of 350 CCA each. Battery size: 7 3/4 L x 5 3/16 W x 7 5/16 H inches (196mm L x 131mm W x 185mm H). This is based on testing in extreme cold and heat -22° F (-30° C) to 104° F (40° C). Purchase batteries locally. Install positive cable first.

Install a cable from the positive (+) terminal of one battery to the negative (-) terminal of the other battery. Always connect the positive (+) battery cable to the generator first.

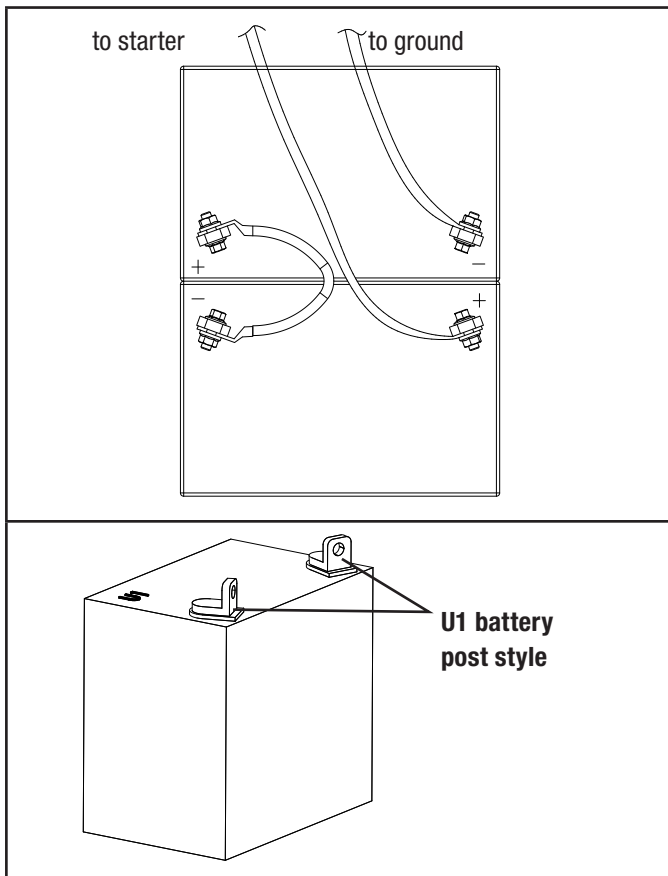

CAUTION

For battery installation, maintenance, and safety requirements refer to purchased manufacturer battery installation and safety manual.

Battery Charging

The generator is equipped with an automatic battery charger. The charger will sense the battery's state of charge and automatically charge the battery when required. LED lights on the charger display the battery state of charge.

Model and Serial Number

The model and serial number plate is affixed to the generator above the control panel. Have this information if calling for service or ordering parts.

| | | | |
|---|------------------------|-------------------------------------|-------------------------|
| STATIONARY ENGINE DRIVEN GENERATOR / STATIONNAIRE GÉNÉRATEUR ENTRAINÉ PAR UN MOTEUR / GENERADOR ACCIONADO POR MOTOR ESTACIONARIO | | MODEL 100515 | |
| RATED VOLTAGE | 120/240-, single-phase | TENSION NOMINALE | 120 / 240-, monofásicas |
| RATED FREQUENCY | 60 Hz | FRECUENCIA NOMINALE | 60 Hz |
| RATED CURRENT | 116.6 A / 58.3 A (LPG) | CORRIANT NOMINALE | 116.6 A / 58.3 A (GPL) |
| POWER FACTOR | 1.0 | FACTEUR DE PUISSANCE | 1.0 |
| MAX LOAD UNBALANCE | 50% | MAX DÉSÉQUILIBRE DE CHARGE | 50 % |
| RATED ENGINE SPEED | 3600 RPM | RÉGIME MOTEUR NOMINALE | 3600 RPM |
| RATED AMBIENT TEMP | 77°-104°F (25°-40°C) | TEMPÉRATURE AMBIANTE NOMINALE | 77°-104°F (25°-40°C) |
| INSULATION CLASS | H | ISOLATION DE CLASSE | H |
| NEUTRAL | FLLOATING | NEUTRE | FLOTTANT |
| FOR STANDBY SERVICE | | POUR LE SERVICE DE SECOURS | |
| RAINFOOF ENCLOSURE FITTED | | BÔÎTE ETANCHE À LA PLUIE ÉQUIPÉE | |
| CHAMPION POWER EQUIPMENT 12039 Smith Ave., Santa Fe Springs, CA 90670 USA | | | |
| | | PARA EL SERVICIO SUPLENTE | |
| | | CARCASA A PRUEBA DE LLUVIA EQUIPADO | |
| | | TEMPERATURA AMBIENTE NOMINALE | 77°-104°F (25°-40°C) |
| | | ASLANTE CLASE | H |
| | | NEUTRAL | FLOTTANTE |
| | | VELOCIDAD NOMINALE DEL MOTOR | 3600 RPM |
| | | MAX DÉSÉQUILIBRIO DE LA CARGA | 50 % |
| | | FACTOR DE POTENCIA | 1.0 |
| | | CORRIENTE NOMINALE | 116.6 A / 58.3 A (GPL) |
| | | FRECUENCIA NOMINALE | 60 Hz |
| | | TENSION NOMINALE | 120 / 240-, monofásicas |
|  Conforms to UL Std. No. 2200 Certified to CAN/CSA Standard C22.2 No. 100 2407-L-PR-A | | | |

OPERATION

Before operating the generator, review **SAFETY** section starting on page 8.

Enclosure and Access

Open the enclosure to gain access to the generator and its components. Unlock the handles. Turn the handles and lift the hoods up and to the outside.



Pre-Start Checklist

To make sure the generator is ready for proper operation, the following items should be checked:

- On/Off switch is in the ON position
- Fuel valve is in the on position
- No fault code LEDs are lit
- Battery is at full charge
- aXis Controller™ module is in AUTO mode.
- Transfer switch is in the Utility Power position

Turning OFF the Generator

If you need to shut off the generator when it is running, turn the engine control module switch to the OFF position. This will shut off the engine. With the engine control module in the OFF position, the generator will not start, even if there is loss of utility power.

MAINTENANCE

Before performing maintenance procedures, review SAFETY section starting on page 8.

Ensure that the ATS and Engine Switches are in the OFF position before performing any maintenance or cleaning.

Scheduled Maintenance Chart

| First 5 Hours of Operation | |
|----------------------------|---|
| Change engine oil | √ |

| Weekly | |
|---|---|
| Check exterior fault code indicator light | √ |
| Inspect and clean enclosure louvers | √ |

| Monthly | |
|-------------------------------------|----|
| Check engine oil level | √* |
| Inspect fuel lines and connections | √ |
| Inspect and clean battery terminals | √ |

| Every 2 Years or 100 Hours of Operation | |
|---|------|
| Change engine oil | √** |
| Inspect and clean engine air cleaner | √** |
| Inspect engine spark plug | √ |
| Complete inspection of generator, engine tune-up, and valve lash check/adjustment | √*** |

** Monthly or 24 hours of continuous operation

*** Service sooner if operating in high ambient temperatures or a dusty and dirty environment.

**** Maintenance should be performed by your service dealer.

Engine Oil

ENGINE OIL REQUIREMENTS

Use American Petroleum Institute (API) Service Class SN or better. Do not use special additives.

NOTICE

The recommended oil type for typical use is **5W-30 full synthetic oil**. However, using the listed conventional oils shown in the "Recommended Engine Oil Type" chart may be used for typical use.

If running generator in extreme temperatures, refer to the "Recommended Engine Oil Type" chart.

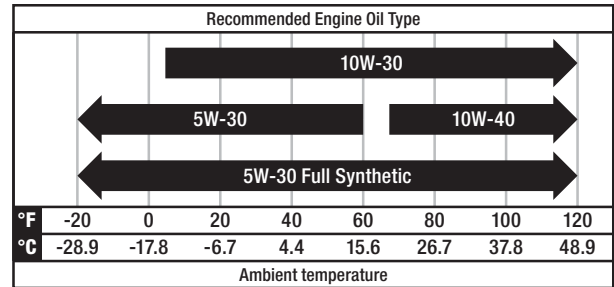

CHECKING THE ENGINE OIL LEVEL

Check the oil level daily when the generator is running for an extended period of time.

1. If the generator is running during a utility outage, turn off all household loads.
2. Turn the engine control module switch to the OFF position.
3. Remove the dipstick. Wipe it dry with a clean cloth and completely reinsert it into the dipstick tube.

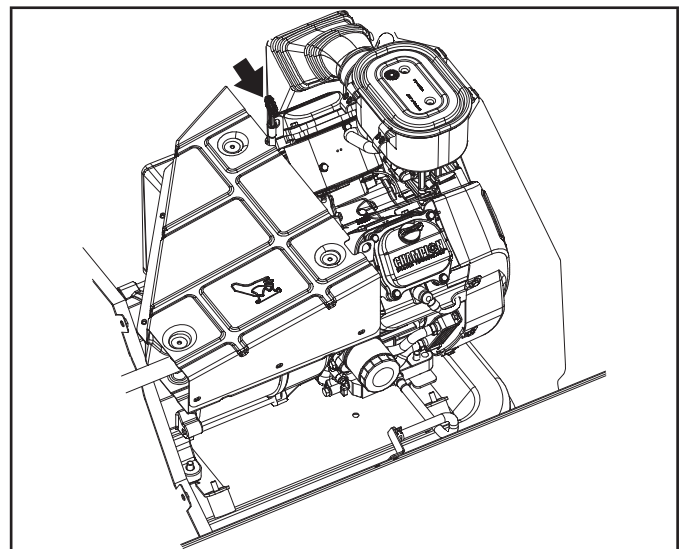

WARNING

DO NOT overfill the engine with engine oil. Damage to the engine may occur.

4. Remove the dipstick. The oil level should be at the FULL mark. If necessary, add oil. DO NOT overfill.

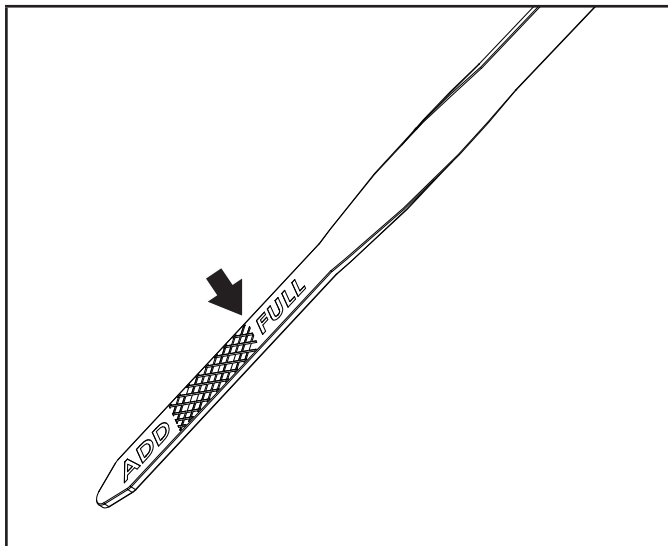

5. Install the dipstick.
6. Turn the engine control module switch to its prior position.

Changing the Engine Oil

⚠ WARNING

Always wear protective glasses or goggles and protective clothing when changing hot engine oil.

1. Turn the ATS to the OFF position.
2. Turn the engine control module switch to the MANUAL position.
3. Allow the engine to run until it reaches operating temperature.
4. Turn the engine control module switch to the OFF position.

🗨 NOTICE

Always be environmentally responsible. Consult the local authorities or reclamations facility for proper disposal of engine oil waste.

5. Position drain pan under alternator.
6. Loosen hose clamp on oil drain hose and slide drain hose off retaining pin.

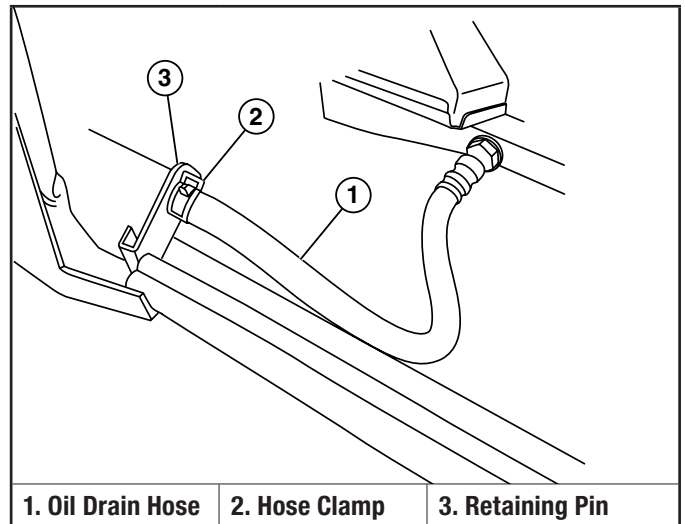

1. Oil Drain Hose 2. Hose Clamp 3. Retaining Pin

7. Position drain hose into drain pan and allow crankcase to empty.
8. Reinstall the hose onto the retaining pin and reposition hose clamp.
9. Fill the engine with the proper amount of engine oil.
10. Turn the engine control module switch to its prior position.
11. Turn the ATS to the AUTO position.

Inspect and Clean Engine Air Cleaner

1. Turn the engine control module switch to the OFF position.
2. Unsnap the clips holding the air cleaner cover in place and remove the air cleaner cover.
3. Remove the paper element.

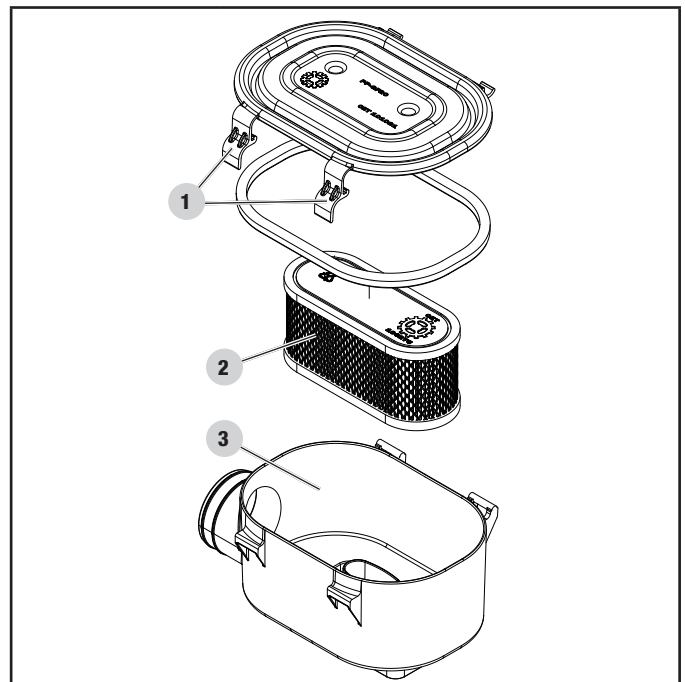

1. Air cleaner cover clips 2. Paper element 3. Air cleaner base

4. Inspect the paper element for any rips or tears. Replace if damaged.
5. Hold the paper element up to a light. You should be able to see light through the paper element, if not replace the element. Inspect air cleaner cover, remove any dirt or debris.
6. Install paper element in the air cleaner housing with the pleats facing towards the air cleaner cover.
7. Install the cover and snap the clips in place.
8. Turn the engine control module switch to its prior position.

Spark Plug

1. Turn the ATS to the OFF position.
2. Turn the engine control module switch to the OFF position.
3. Remove the spark plug cable from the spark plug.
4. Clean the area around the spark plug to keep dirt out of the engine and remove the spark plug.
5. Inspect the spark plug electrode and replace the plug if the electrode shows signs of deterioration.
6. Check the gap before installing the spark plug. The spark plug gap should be 0.028 – 0.031 in. (0.7 – 0.8 mm).

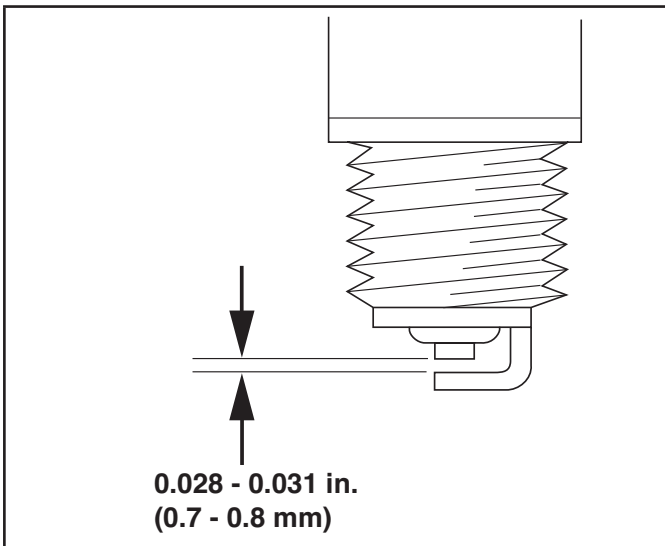

7. Carefully thread the spark plug into the engine and tighten to 20-30 N-m (14.8-22.1 lbf-ft).
8. Re-connect the spark plug cable.
9. Turn the engine control module switch to its prior position.
10. Turn the ATS to the AUTO position.

Battery Maintenance

1. Turn the engine control module switch to the OFF position.
2. Inspect the battery cables and terminals for corrosion.
3. Check that the cables are securely fastened to the terminals.
4. Check the ground lug and make sure the connections are tight.
5. Check the fluid level of the battery, unless sealed. If low, top off the level using distilled water only.

Follow all battery instructions provided by the battery manufacture.

Corrosion Protection

NOTICE

Never use a pressure washer to wash the interior of the generator with water.

Wash the outside of the enclosure using a mild soap and water. Use an automotive-type wax and wax the outside of the enclosure to protect it from the elements. If used in a salt water/coastal area, the enclosure should be washed more frequently to prevent corrosion. Spray light oil on the hinges for the enclosure doors.

Maintenance After Submersion

WARNING

Never try to start or operate the generator if it has been submerged underwater or exposed to a flood.

If the generator has been in conditions where it became submerged underwater, the generator must be inspected and maintenance must be performed before returning the generator to service.

Turn engine control module and ATS control module to the OFF position. Have a authorized Champion Dealer inspect the generator and perform any necessary maintenance.

If the house or building has been exposed to a flood, it should be inspected by a certified electrician for any electrical problems that may occur if the generator is put back into service or if utility power is restored.

Storage

If the generator is not going to be used for several months and not exercised every 7 days, it should be prepared for storage.

1. Manually start the engine and run it for several minutes to allow it to warm up.
2. With the engine running, turn the fuel shutoff valve to the closed position and let the engine continue to run until it shuts down.
3. Once the engine has shut down, turn the engine control module switch and the ATS control module switch to the OFF position.
4. Switch the generator's main circuit breaker to the OFF (OPEN) position.
5. Turn off the utility power to the transfer switch.
6. Disconnect the battery cables. Remove the negative cable first.
7. Change the engine oil. See Changing the Engine Oil on page 25.
8. Remove the spark plug and spray fogging oil into the spark plug hole. Install the spark plug and tighten.
9. Thoroughly wash and wax the exterior of the generator enclosure. Do not use a pressure washer.
9. Make sure there are not any active fault codes.
10. Turn the engine control module switch to the OFF position to shut off the engine.
11. Turn the ATS module switch to the AUTO position.
12. Turn on the utility power to the transfer switch. The utility LEDs on the ATS module should be lit.
13. Turn the engine control module switch to the ATS position.
14. Set the exercise time.

Return to Service after Storage

1. Make sure the utility power to the transfer switch is off.
2. The engine control module switch and the ATS control module switch should be in the OFF position.
3. Check the engine oil level. Add oil if needed.
4. Recharge the batteries to 100% state of charge. If the batteries will not fully charge, replace the batteries.

WARNING

Always connect the positive (+) battery cable first. After the positive cable is connected, then the negative (-) battery cable can be attached. This minimizes the possibility of electrical contact.

5. Connect the positive (+) battery cable to the positive (+) battery terminal first and then connect the negative battery cable to the negative (-) battery terminal.
6. Clean and wipe down the generator with mild soap and water.
7. Turn the fuel shutoff valve to the ON position.
8. Turn the engine control module switch to the manual position. The engine should start. Run the engine for 15 minutes to allow it to warm up. The fuel system might require more than one start cycle to fully pressurize the fuel system for operation.

TROUBLESHOOTING HSB

| Engine will not crank/turn over | | |
|---------------------------------|---|--|
| 1 | HSB set in "OFF" mode. | Place the HSB controllers in the AUTO position. |
| 2 | Battery not connected or loose, corroded posts or wires | Connect the batteries according to owner's manual, clean and tighten the battery connections |
| 3 | Battery(s) not charged or low charge. | Recharge or replace battery(s). |
| 4 | Check for active fault code. | Identify fault code, correct and reset. |
| 5 | Defective starter solenoid * | |
| 6 | Defective starter * | |

| Generator will crank/turn over but will not start | | |
|---|--------------------------------------|--|
| 1 | Check for active fault code. | Identify fault code, correct and reset. |
| 2 | Fuel valve(s) turned off. | Turn on fuel supply. |
| 3 | Fuel pressure insufficient*. | Manometer check, confirm fuel pressure to fuel regulator*. |
| 4 | Weak battery(s). | Recharge or replace battery(s) |
| 5 | Low oil level. | Check for oil leaks. Check the oil level and add oil if necessary. |
| 6 | Spark plug wire is disconnected. | Connect spark plug wire. |
| 7 | Defective fuel solenoid/regulator. * | |

| Engine starts, runs rough | | |
|---------------------------|---|---|
| 1 | Fuel pressure insufficient*. | Manometer check, confirm fuel pressure to fuel regulator*. |
| 2 | Wrong fuel jets. | Check jets for NG or LPG, change to correct Master Mixer fuel jets. |
| 3 | Faulty spark plug, loose spark plug wire. | Change spark plug, set gap, connect wire. |
| 4 | Plugged air cleaner | Clean or replace air cleaner. |
| 5 | Generator overloaded*. | Remove one or more loads*. |
| 6 | Shorted circuit * | |

| HSB starts, then suddenly stops | | |
|---------------------------------|--|--|
| 1 | Check for active fault code. | Identify fault code, correct and reset. |
| 2 | Fuel supply insufficient* | Manometer check, confirm fuel pressure to fuel regulator*. |
| 3 | Low oil, pressure shut down | Check for oil leaks. Check the oil level and add oil if necessary. |
| 4 | Generator over loaded | Turn off standby circuits for house, reset fault, place unit back into AUTO mode. Turn on standby circuits for house. If problem returns contact Champion or Champion service dealer*. |
| 5 | Engine high/over temperature shut down | Check all intake and exhaust ventilation around the HSB, remove all debris. Let HSB sit for 30 minutes to cool down. |

| No AC output | | |
|--------------|--|------------------|
| 1 | Circuit breaker in "OFF" position | Turn on breaker. |
| 2 | Main circuit breaker in "OFF" position. | Turn on breaker. |
| 3 | Transfer switch breaker in "OFF" position. | Turn on breaker. |
| 4 | Standby breakers set in "OFF" position. | Turn on breaker. |
| 5 | Line circuit tripping breaker because of short circuit * | |
| 6 | Line circuit tripping breaker because of overload * | |
| 7 | Poor wiring connections* | |
| 8 | ATS problems* | |

Reset fault code(s)

There is an exterior fault code indicator light located on the back of the enclosure. This should be checked weekly to make sure there are no active fault codes.

BATTERY(S) NO OR LOW LEVEL CHARGED, BATTERY(S) DEAD, NEEDS REPLACEMENT, THE EXERCISE TIME MUST BE RESET ONCE THE BATTERY(S) HAVE BEEN DISCONNECTED.

***Contact Champion Power Equipment, Technical Service toll free 1-877-338-0999, tech@championpowerequipment.com or your nearest Champion dealer.*

www.championpowerequipment.com

ADDITIONAL INFORMATION

Identify/Select Standby Circuits

Identify the basic needs

It is very important to understand what items the home owner wants powered by the HSB during a utility failure. The selection of these items will indicate which circuits will be selected for connection to the ATS so that they are powered by the HSB. Unforeseen power outages can last from minutes to days, so it is important to focus circuit selections on those that power household items that are deemed essential and within the output capability of the HSB

An authorized or certified dealer or electrician can come to your home and measure the loads with a clamp-on AMP meter which would provide accurate load demands for each circuit tested.

Once you have identified the customer needs, you can properly size the HSB by referring to the sizing guide provided by Champion, www.championpowerequipment.com or call Champion 1-877-338-0999.

Circuits must be protected by the same size breaker. For example, a 15 amp 120 volt circuit in the ATS will replace a 15 amp 120 volt circuit in the main utility distribution panel. When tied together or backed up, the breakers must be the same size.

Surge Protection

⚠ CAUTION

Voltage fluctuation may impair the proper functioning of sensitive electronic equipment.

Electronic devices, including computers and many programmable appliances use components that are designed to operate within a narrow voltage range and may be affected by momentary voltage fluctuations. While there is no way to prevent voltage fluctuations, you can take steps to protect sensitive electronic equipment.

1. Install UL1449, CSA-listed, plug-in surge suppressors on the outlets feeding your sensitive equipment. Surge suppressors come in single or multi-outlet styles. They're designed to protect against virtually all short-duration voltage fluctuations.

Customer Familiarization Summary

It's important to educate the home owner on proper maintenance, operation and service call procedures. A properly educated home owner can reduce unnecessary service trips and phone calls.

Ensure that the installation of the HSB and ATS has been correctly performed as outlined by the manufacturer and that it meets all applicable codes.

Test and confirm proper operation of the HSB and ATS system as outlined in the appropriate installation and owner's manuals.

Educate the home owner on the location and operation of;

- Full flow shutoff valve
- Automatic operation of the HSB system
- Battery Charger and LED indicators
- Exterior fault code indicator LED on the backside of the HSB
- ATS operation
- Exercise scheduled time of operation
- Scheduled Maintenance
- Fill out and provide the customer a copy of the HSB, ATS model & serial number reference. This information is extremely important for part purchases and service information, these numbers are specific to each HSB and ATS.
- Fill out and provide the customer a copy of the ATS back-up circuits.
- Fill out the Circuit Label inside the ATS.

It's always a good business practice to place business cards in the Owner's and Installation manuals and place dealer stickers on the HSB and ATS for the customer's reference.

HSB, ATS Model & Serial Reference ATS Back-up Circuits

HSB Model Number _____

HSB Serial Number _____

Fuel Type LPG _____ NG _____

ATS Model Number _____

ATS Serial Number _____

ATS circuits powered _____

Date Installed _____

Dealer/Installer _____

Address _____

Phone _____

Cell _____

Purchased from _____

Maintenance and Service Record

Keeping accurate records when any service is preformed is important. Records replace guessing when a repair was done or when it should be scheduled. Hour Meter notation as well as the date provides better time period records. To maintain the overall performance throughout the life of the product follow the scheduled maintenance chart contained in your owner's manual or refer to www.championpowerequipment.com. Genuine Champion parts must be used to ensure warranty coverage.

Date _____

Hour Meter _____

Service Preformed _____

Record the name, address and phone number of your authorized Champion dealer



10 Year Limited Warranty* Basic Warranty Provisions

Champion Air-Cooled 8.5kW – 20kW Home Standby Units USA and Canadian Models

For a period of 10 years or 2000 hours (whichever occurs first) from successful activation by an Authorized Champion Home Standby Dealer, Champion Power Equipment will, at its option, repair or replace any part(s) which upon examination, inspection and testing by Champion Power Equipment or an Authorized Champion Home Standby Dealer is found to be defective under normal use and service, in accordance with the Warranty Schedule set forth below.

Any equipment that the purchaser/owner claims to be defective must be examined by the nearest Authorized/Certified Champion Home Standby Service Dealer. This warranty applies only to Champion Power Equipment automatic standby generators used in "Standby" applications as Champion has defined Standby. Scheduled Maintenance, as outlined by the generator owner's manual is required. This Scheduled Maintenance should be performed by an Authorized/Certified Champion Home Standby Service Dealer.

WARRANTY SCHEDULE

Years 1 and 2 – Limited comprehensive coverage on mileage, labor and parts
Years 3 through 10 – Limited comprehensive coverage on parts only

GUIDELINES:

- Warranty begins upon the successful activation of the unit.
- Unit should be Registered and Proof of Purchase and Maintenance must be available.
- Warranty is transferable between ownership of original installation site.
- Warranty only applies to permanently wired and mounted units.
- Any and all warranty repairs and/or concerns must be performed and/or addressed by an Authorized/Certified Champion Home Standby Service Dealer. Repairs or diagnostics performed by individuals other than Authorized/Certified Champion Home Standby Service Dealers not authorized in writing by Champion Power Equipment will not be covered.
- A Champion approved Transfer Switch is highly recommended to be used in conjunction with the generator set. The Champion Transfer Switch is covered under its own, separate warranty listed in the Transfer Switch Instruction Manual and is not covered under this warranty schedule.
- If a Non-Champion approved Transfer Switch is substituted for use and directly causes damage to the generator set, no warranty coverage shall apply.
- Steel enclosures are warranted against rusting for the first year of ownership only. Damage caused after receipt of generator is the responsibility of the owner and is not covered by this warranty. Nicks, scrapes, dents or scratches to the painted enclosure should be repaired promptly by the owner.
- All warranty expense allowances are subject to the conditions defined in Champion Power Equipment "Home Standby" Warranty Policy and Procedures Manual.

THIS WARRANTY SHALL NOT APPLY TO THE FOLLOWING:

Original installation or start-up costs

Champion Home Standby generators that utilize non-Champion Power Equipment replacement parts

Costs of normal maintenance (i.e. tune-ups, associated part(s), adjustments, loose/leaking clamps, installation and start-up)

Units sold, rated or used for "Prime Power", "Trailer Mounted" or "Rental Unit" applications

Damage to generator system (including transfer switch) caused by improper installation or costs necessary to correct installation

Units used for Prime Power in place of existing utility power (where utility power is present) or in place of utility power where utility power service does not normally exist. Prime power includes any application that does not use the utility grid for electric power (example: Solar power)

Fuel connections other than conventional utility company supplied natural gas systems or conventional LP vapor withdrawal systems

Any failure caused by contaminated fuels, oils or lack of proper fuels, oils or failure to perform scheduled maintenance and service the air filter

Steel enclosures that are rusting due to the improper installation, location in a harsh or saltwater environment or scratched where integrity of paint applied is compromised

Failures due, but not limited, to normal wear and tear, accident, misuse, abuse, negligence or improper installation. As with all mechanical devices, the Champion engines need periodic part(s) service and fluid replacement to perform as designed.

Failures caused by any external cause or act of God, such as collision, theft, vandalism, riot or wars, nuclear holocaust, fire, freezing, lightning, earthquake, windstorm, hail, volcanic eruption, water or flood, tornado or hurricane

Damage related to rodent and/or insect infestation

Covered warranty labor rates are based on normal working hours. Overtime, holiday, or emergency labor costs for repairs outside of normal business hours will be the responsibility of the customer

Any incidental, consequential or indirect damages caused by defects in materials or workmanship, or any delay in repair or replacement of the defective part(s)

Failure due to misapplication to provide sufficient cooling air and to regularly exercise the generator under load

Telephone, cellular phone, facsimile, internet access or other communication expenses

Living or travel expenses of person(s) performing service, except as specifically included within the terms of a specific unit warranty period

Expenses related to "customer instruction" or troubleshooting where no manufacturing defect is found

Rental equipment used while warranty repairs are being performed and/or overnight freight costs for replacement part(s)

Costs incurred for equipment used for removal and/or reinstallation of generator, (i.e.: cranes, hoists, lifts, etc.)

Planes, ferries, railroad, buses, helicopters, snowmobiles, snow-cats, off-road vehicles or any other mode of transport deemed abnormal

Starting batteries, fuses, light bulbs, engine fluids, and spark plugs

THIS WARRANTY AND THE ATTACHED U.S. EPA and/or CARB WARRANTY ARE IN LIEU OF ALL OTHER WARRANTIES, EXPRESS OR IMPLIED, INCLUDING WARRANTIES OF MERCHANTABILITY OR FITNESS FOR A PARTICULAR PURPOSE.

Any implied warranties which are allowed by law, shall be limited in duration to the terms of the express warranty provided herein. Some states do not allow limitations on how long an implied warranty lasts, so the above limitation may not apply to purchaser/owner.

CHAMPION POWER EQUIPMENT'S ONLY LIABILITY SHALL BE THE REPAIR OR REPLACEMENT OF PART(S) AS STATED ABOVE. IN NO EVENT SHALL CHAMPION POWER EQUIPMENT BE LIABLE FOR ANY INCIDENTAL, OR CONSEQUENTIAL DAMAGES, EVEN IF SUCH DAMAGES ARE A DIRECT RESULT OF CHAMPION POWER EQUIPMENT'S NEGLIGENCE.

Some states do not allow the exclusion or limitation of incidental or consequential damages, so the above limitations may not apply to purchaser/owner. Purchaser/owner agrees to make no claims against Champion Power Equipment based on negligence. This warranty gives purchaser/owner specific legal rights. Purchaser/owner also may have other rights that vary from state to state.

To obtain warranty service or your nearest Champion Home Standby Dealer call Champion Power Equipment Customer Service toll free 1-877-338-0999.

Contact Information

Address

Champion Power Equipment, Inc.
Customer Service
12039 Smith Avenue
Santa Fe Springs, CA 90670
www.championpowerequipment.com

Customer Service and Technical Support

Toll Free: 1-877-338-0999
hsb@cpeauto.com
Fax No.: 1-562-236-9429

*Except as otherwise stipulated in any of the following enclosed Emission Control System Warranties (when applicable) for the Emission Control System: U.S. Environmental Protection Agency (EPA) and/or California Air Resources Board (CARB).

**CHAMPION POWER EQUIPMENT, INC. (CPE)
AND THE UNITED STATES ENVIRONMENT PROTECTION AGENCY (U.S. EPA)
EMISSION CONTROL SYSTEM WARRANTY**

Your Champion Power Equipment (CPE) engine complies with U.S. EPA emission regulations.

YOUR WARRANTY RIGHTS AND OBLIGATIONS:

The US EPA AND CPE are pleased to explain the Federal Emission Control Systems Warranty on your 2020 small off-road engine (SORE) and engine powered equipment. New engines and equipment must be designed, built and equipped, at the time of sale, to meet U.S. EPA regulations for small off-road engines (SORE). CPE warrants the emission control system on your small off-road engine (SORE) and equipment for the period of time listed below, provided there has been no abuse, neglect, unapproved modification, or improper maintenance of your equipment.

Your emission control system may include parts such as the carburetor, fuel-injection system, the ignition system, catalytic converter and fuel lines. Also included may be hoses, belts, connectors and other emission related assemblies. Where a warrantable condition exists, CPE will repair your small off-road engine (SORE) at no cost to you including diagnosis, parts and labor.

MANUFACTURER'S EMISSION CONTROL SYSTEM WARRANTY COVERAGE:

This emission control system is warranted for two years, subject to provisions set forth below. If, during the warranty period, an emission related part on your engine is defective in materials or workmanship, the part will be repaired or replaced by CPE.

OWNER WARRANTY RESPONSIBILITIES:

As the small off-road engine (SORE) owner, you are responsible for the performance of the required maintenance listed in your Owner's Manual. CPE recommends that you retain all your receipts covering maintenance on your small off-road engine (SORE), but CPE cannot deny warranty solely for the lack of receipts or for your failure to ensure the performance of all scheduled maintenance.

As the small off-road engine (SORE) owner, you should however be aware that CPE may deny you warranty coverage if your small, off-road engine (SORE) or a part has failed due to abuse, neglect, improper maintenance or unapproved modifications.

You are responsible for presenting your small off-road engine (SORE) to an Authorized CPE service outlet or alternate service outlet as described in (3)(f.) below, CPE dealer or CPE, Santa Fe Springs, Ca. as soon as a problem exists. The warranty repairs should be completed in a reasonable amount of time, not to exceed 30 days.

If you have any questions regarding your warranty rights and responsibilities, you should contact:

Champion Power Equipment, Inc.
Customer Service
12039 Smith Ave.
Santa Fe Springs, CA 90670
1-877-338-0999
tech@championpowerequipment.com

EMISSION CONTROL SYSTEM WARRANTY

The following are specific provisions relative to your Emission Control System (ECS) Warranty Coverage.

- 1. APPLICABILITY:** This warranty shall apply to 1997 and later model year small off-road engines (SORE). The ECS Warranty Period shall begin on the date the new engine or equipment is delivered to its original, end-use purchaser, and shall continue for 24 consecutive months thereafter.
- 2. GENERAL EMISSIONS WARRANTY COVERAGE**

CPE warrants to the original, end-use purchaser of the new engine or equipment and to each subsequent purchaser that each of its small off-road engines (SORE) is:

 - 2a. Designed, built and equipped so as to conform to U.S. EPA emissions standards for spark-ignited engines at or below 19 kilowatts.
 - 2b. Free from defects in materials and workmanship that cause the failure of a warranted part to be identical in all material respects to the part as described in the engine manufacturer's application for certification for a period of two years.
- 3. THE WARRANTY ON EMISSION-RELATED PARTS WILL BE INTERPRETED AS FOLLOWS:**
 - 3a. Any warranted part that is not scheduled for replacement as required maintenance in the Owners Manual shall be warranted for the ECS Warranty Period. If any such part fails during the ECS Warranty Period, it shall be repaired or replaced by CPE according to Subsection "d" below. Any such part repaired or replaced under the ECS Warranty shall be warranted for any remainder of the ECS Warranty Period.
 - 3b. Any warranted, emissions-related part which is scheduled only for regular inspection as specified in the Owners Manual shall be warranted for the ECS Warranty Period. A statement in such written instructions to the effect of "repair or replace as necessary", shall not reduce the ECS Warranty Period. Any such part repaired or replaced under the ECS Warranty shall be warranted for the remainder of the ECS Warranty Period.
 - 3c. Any warranted, emissions-related part which is scheduled for replacement as required maintenance in the Owner's Manual shall be warranted for the period of time prior to the first scheduled replacement point for that part. If the part fails prior to the first scheduled replacement, the part shall be repaired or replaced by CPE according to Subsection "d" below. Any such emissions-related part repaired or replaced under the ECS Warranty, shall be warranted for the remainder of the ECS Warranty Period prior to the first scheduled replacement point for such emissions-related part.
 - 3d. Repair or replacement of any warranted, emissions-related part under this ECS Warranty shall be performed at no charge to the owner at a CPE Authorized Service Outlet.
 - 3e. The owner shall not be charged for diagnostic labor which leads to the determination that a part covered by the ECS Warranty is in fact defective, provided that such diagnostic work is performed at a CPE Authorized Service Outlet.
 - 3f. CPE shall pay for covered emissions warranty repairs at non-authorized service outlets under the following circumstances:
 - i. The service is required in a population center with a population over 100,000 according to U.S. Census 2000 without a CPE Authorized Service Outlet AND
 - ii. The service is required more than 100 miles from a CPE Authorized Service Outlet. The 100 mile limitation does not apply in the following states: Alaska, Arizona, Colorado, Hawaii, Idaho, Montana, Nebraska, Nevada, New Mexico, Oregon, Texas, Utah and Wyoming.
 - 3g. CPE shall be liable for damages to other original engine components or approved modifications proximately caused by a failure under warranty of an emission-related part covered by the ECS Warranty.
 - 3h. Throughout the ECS Warranty Period, CPE shall maintain a supply of warranted emission-related parts sufficient to meet the expected demand for such emission-related parts.
 - 3i. Any CPE Authorized and approved emission-related replacement part may be used in the performance of any ECS Warranty maintenance or repair and will be provided without charge to the owner. Such use shall not reduce CPE's warranty obligation.
 - 3j. Unapproved add-on or modified parts may not be used to modify or repair a CPE engine. Such use voids this ECS Warranty and shall be sufficient grounds for disallowing an ECS Warranty claim. CPE shall not be liable hereunder for failures of any warranted parts of a CPE engine caused by the use of such an unapproved add-on or modified part.

EMISSION-RELATED PARTS INCLUDE THE FOLLOWING: (using those portions of the list applicable to the engine)

| Systems covered by this warranty | Parts Description |
|---|---|
| Fuel Metering System | Fuel regulator, Carburetor and internal parts |
| Air Induction System | Air cleaner, Intake manifold |
| Ignition System | Spark plug and parts, Magneto ignition system |
| Exhaust System | Exhaust manifold, catalytic converter |
| Miscellaneous Parts | Tubing, Fittings, Seals, Gaskets, and Clamps associated with these listed systems. |
| Evaporative Emissions | Fuel Tank, Fuel Cap, Fuel Line (for liquid fuel and fuel vapors), Fuel Line Fittings, Clamps, Pressure Relief Valves, Control Valves, Control Solenoids, Electronic Controls, Vacuum Control Diaphragms, Control Cables, Control Linkages, Purge Valves, Gaskets, Vapor Hoses, Liquid/Vapor Separator, Carbon Canister, Canister Mounting Brackets, Carburetor Purge Port Connector |

TO OBTAIN WARRANTY SERVICE:

You must take your CPE engine or the product on which it is installed, along with your warranty registration card or other proof of original purchase date, at your expense, to any Champion Power Equipment dealer who is authorized by Champion Power Equipment, Inc. to sell and service that CPE product during his normal business hours. Alternate service locations defined in Section (3)(f.) above must be approved by CPE prior to service. Claims for repair or adjustment found to be caused solely by defects in material or workmanship will not be denied because the engine was not properly maintained and used.

If you have any questions regarding your warranty rights and responsibilities, or to obtain warranty service, please write or call Customer Service at Champion Power Equipment, Inc.

Champion Power Equipment, Inc.
12039 Smith Ave.
Santa Fe Springs, CA 90670
1-877-338-0999
Attn.: Customer Service
tech@championpowerequipment.com